

R 5

0004 - 1600

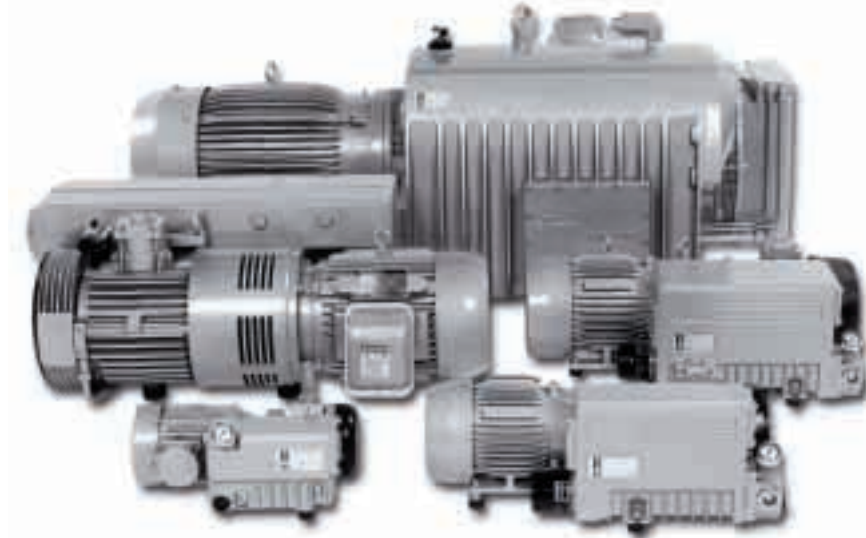

R 5 Series Vacuum Pumps

Description

Modular designed Busch R 5 oil sealed rotary vane vacuum pumps are single stage, air-cooled, and direct driven. This oil-recirculating design is one of the simplest and most reliable vacuum pumps available on the world market. These rugged pumps are used in a variety of industries such as packaging and food processing, rubber molding, thermoforming, printed circuit board testing, hospitals, laboratories, robotics, vacuum lamination, printing, and many others.

Displacements range from 3 to 1130 CFM. Three models are available: the RC for applications to 15 torr (29.3" Hg); the RB for applications to 2 torr (29.8" Hg); and the RA for applications to 0.5 torr (29.9" Hg).

R 5 Advantages

- Compact, simple design for easy installation and low maintenance
- Air-cooled, requiring no water
- Direct drive, eliminating belts and gears to loosen or wear
- Oil mist eliminator for 99.9% oil-free exhaust
- Quiet operation
- Water-cooled versions available
- Improved oil-free exhaust and cooling (on some models)
- Continuous duty
- Easy exhaust filter change
- High quality US made motors

Standard Equipment

- TEFC motor
- Motor starter (optional)
- NPT inlet on most models
- Exhaust pressure gauge
- Anti-suckback valve
- Built-in exhaust filter
- Wire mesh inlet screen
- Non-metallic, non-asbestos vanes
- Vibration isolators
- Automotive type spin-on oil filter on most models
- Oil level sight glass

Oil-sealed, rotary vane vacuum pumps

Operating Principle

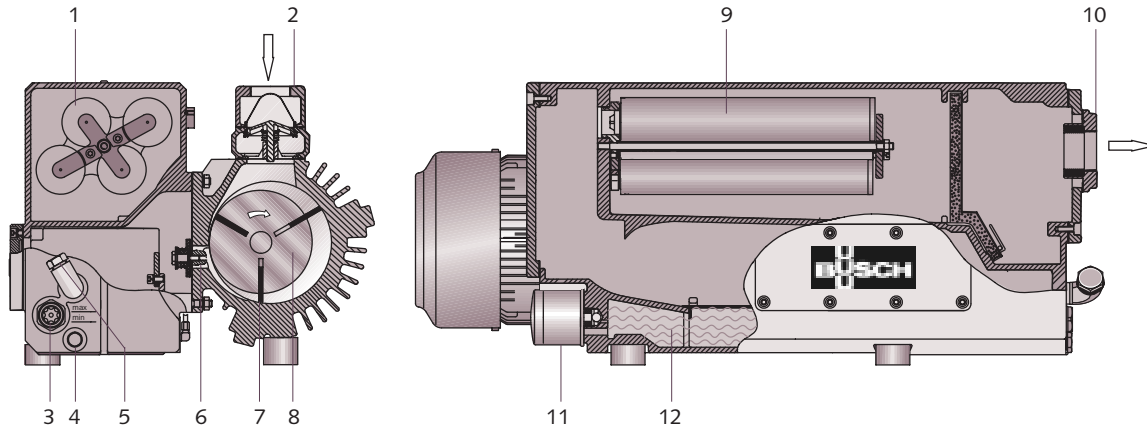

- 1 Oil mist separator
- 2 Inlet flange
- 3 Oil sight glass
- 4 Oil drain plug

- 5 Oil fill plug
- 6 Exhaust valve
- 7 Vane
- 8 Rotor

- 9 Discharge filter
- 10 Exhaust cover plate
- 11 Oil filter
- 12 Oil sump

Operating Principle

Rotation of the pump rotor, which is mounted eccentrically in the pump cylinder, traps entering vapor between rotor vane segments. As rotation continues, vapor is compressed and discharged into the exhaust box.

Vapors then pass through several stages of internal oil and mist eliminators to remove 99.9% of lubricating oil from the exhaust.

Oil is then returned to the oil reservoir. Additional features include an automotive type spin-on oil filter, and a built-in inlet anti-suckback valve that prevents the pump from rotating backwards.

A built-in gas ballast permits pumping with high water vapor loads and provides oil drying for maximum performance.

Technical Data

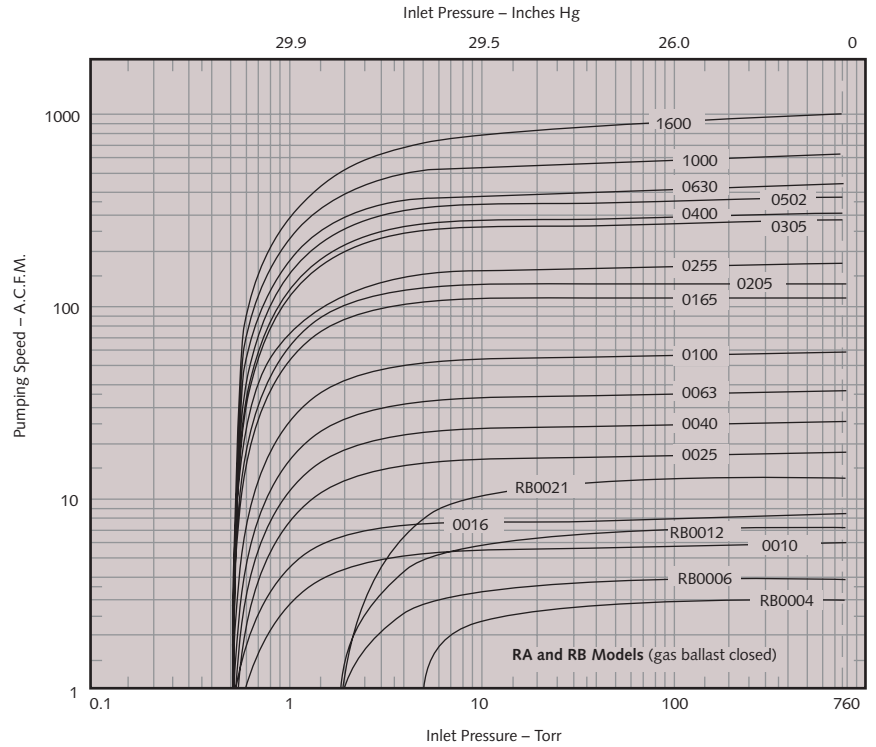

Technical Data	Technical Data						
R 5 Model	0004	0006	0010	0012	0016	0021	0025
Nominal pumping speed (ACFM)	3.3	3.9	6	7	8.6	14	18
Free air displacement (CFM)	3	4.2	7.1	8.5	11.2	15	20
Max. sound level (dBA)	58	62	69	68	70	72	70
Motor size for 3 phase (HP)	NA	1/2	3/4	3/4	3/4	1	1 1/2
Motor size for 1 phase (HP)	3/8	1/2	1	3/4	1	1 1/4	1 1/2
Motor rotational speed (rpm)	1750	3550	1750	1750	1750	3550	1750
Approx. oil capacity, (qt.)*	0.1	0.1	0.5	0.5	0.5	0.5	1.4
Inlet connections — NPT (inch)	3/8	3/8	3/4	1" Hose	3/4	1" Hose	1 1/4
End Vacuum Torr (RC)	NA	NA	15	15	15	15	15
End Vacuum Torr (RA) ¹	5**	2**	0.5	2**	0.5	2**	0.5
Approximate weight (lbs.)	27	28	49	42	60	42	106

*We recommend Busch R-530 vacuum pump oil for most applications; Busch R-580 vacuum pump oil for models 0004, 0006 and 0021; and Busch R-550 vacuum pump oil for models 0010, 0012, 0016, 0025 and RB0004.
 ** RB version for Models 0004, 0006, 0012, and 0021. 1. Models 0165-0630 are continuous duty. Consult factory for special applications.

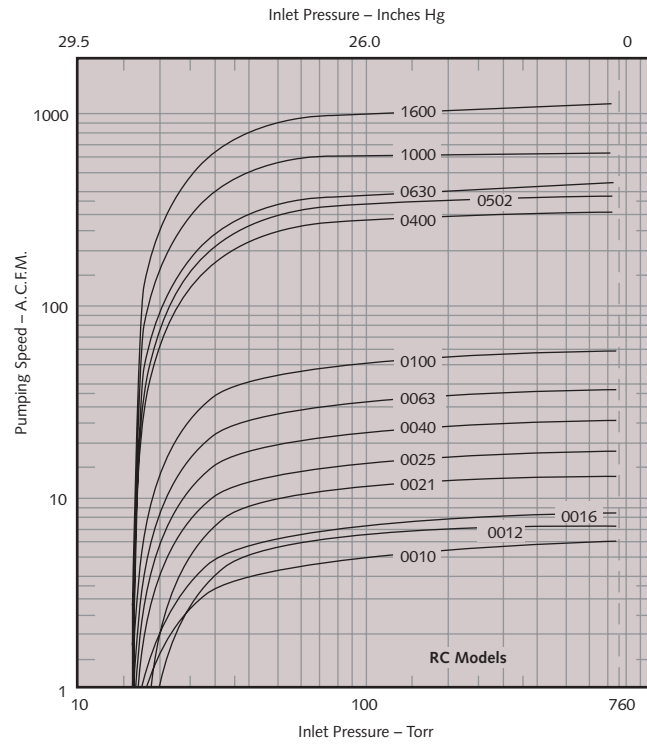

0040	0063	0100	0165	0205	0255	0305	0400	0502	0630	1000	1600
26	36	56	115	130	170	196	305	375	455	670	1030
28	41	63	117	141	180	212	330	413	490	704	1130
70	70	71	79	79	81	81	83	84	85	85	86
2	3	5	7.5	7.5	10	12	15	20	25	40	50
2	3	5	NA	NA	NA	NA	NA	NA	NA	NA	NA
1750	1750	1750	1750	1750	1750	1750	1150	1150	1150	1150	1150
1.4	2.5	2.7	7	7	7	7	14	16	16	42	44
1 ¹ / ₄	1 ¹ / ₄	1 ¹ / ₄	2	2	2	2	3	3	3	6 (ASA)	6 (ASA)
15	15	15	NA	NA	NA	NA	15	15	15	15	15
0.5	0.5	0.5	0.5	0.5	0.5	0.5	0.5	0.5	0.5	0.5	0.5
120	172	198	416	435	460	575	1152	1316	1525	2151	2833

90 for severe applications.



Applications
R 5 0004 - 1600

- Pneumatic suction conveying
- Transport and lifting systems
- Medical technology
- Central vacuum systems
- Woodworking
- Plastic industry
- Ceramics and brick industry
- Printing Industry
- Environmental technology
- Vacuum sewage
- Textile industry
- Food industry
- Beverage industry
- Packaging industry
- Paper industry



Dimensions

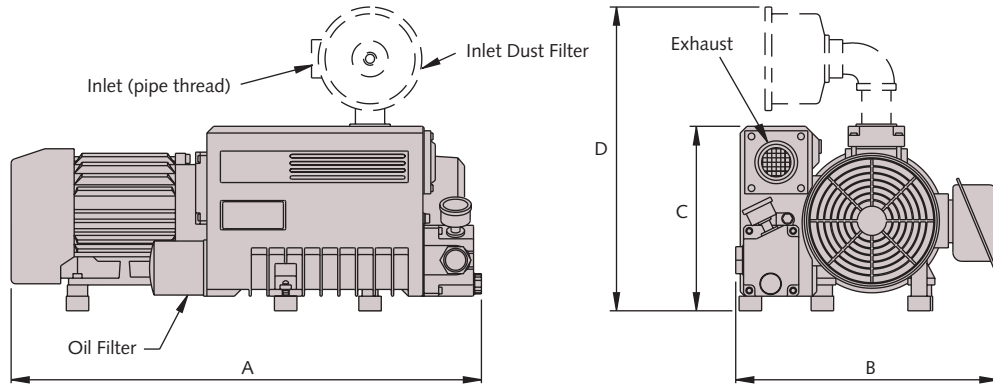

R 5 0025 shown

Dimensions	A length	B width	C height	D height*	Dimensions	A length	B width	C height	D height*
R 5 0004	12 ¹ / ₈	7 ¹ / ₈	7	NA	R 5 0165	40 ¹ / ₂	23 ⁹ / ₁₆	16 ¹ / ₂	25 ³ / ₈
R 5 0006	12	7 ¹ / ₂	6 ¹ / ₈	NA	R 5 0205	40 ¹ / ₂	23 ⁹ / ₁₆	16 ¹ / ₂	25 ³ / ₈
R 5 0010	18 ¹ / ₄	10 ¹ / ₄	7 ⁷ / ₈	11 ⁷ / ₈	R 5 0255	43 ⁵ / ₈	23 ⁹ / ₁₆	16 ¹ / ₂	25 ³ / ₈
R 5 0012	16 ⁵ / ₈	11	6 ³ / ₄	10 ⁵ / ₈	R 5 0305	43 ⁵ / ₈	23 ⁹ / ₁₆	16 ¹ / ₂	25 ³ / ₈
R 5 0016	19 ¹ / ₂	8 ¹ / ₂	8	11 ⁷ / ₈	R 5 0400	54 ³ / ₈	36 ³ / ₈	26 ¹ / ₂	38 ¹ / ₄
R 5 0021	17 ¹ / ₄	11 ⁷ / ₁₆	7 ³ / ₁₆	10 ⁵ / ₈	R 5 0502	67 ¹ / ₁₆	37 ³ / ₄	26 ¹ / ₂	38 ¹ / ₄
R 5 0025	26 ¹ / ₈	14 ⁹ / ₁₆	10 ³ / ₈	17 ¹ / ₈	R 5 0630	70 ¹ / ₈	37 ³ / ₄	26 ¹ / ₂	38 ¹ / ₄
R 5 0040	26 ¹³ / ₁₆	14 ⁹ / ₁₆	10 ³ / ₈	17 ¹ / ₈	R 5 1000	75	45 ³ / ₄	36 ³ / ₄	57
R 5 0063	28	19 ⁵ / ₁₆	11 ⁷ / ₈	18 ¹ / ₄	R 5 1600	87 ³ / ₄	45 ³ / ₄	36 ³ / ₄	57
R 5 0100	29 ¹ / ₂	19 ⁵ / ₁₆	11 ⁷ / ₈	18 ³ / ₄					

All dimensions in inches unless otherwise noted.
 Dimensions may vary depending on motor specs.
 * with filter



Busch - all over the world in industry

ISO 9001 Registered Company

Busch, Inc. 516 Viking Drive Virginia Beach, VA 23452
Phone (757) 463-7800 FAX (757) 463-7407

www.buschpump.com
1-800-USA-PUMP

Amsterdam Barcelona Birmingham Basel Brussels Dublin Göteborg Helsinki Istanbul Copenhagen Kuala Lumpur Milan Maulburg Melbourne Montreal Moscow
 New York New Plymouth Oslo Paris San Jose São Paulo Seoul Singapore Taipei Tokyo Vienna

Models and specifications are subject to change without notice